

PHIX Cooling Carrier – User Manual

The PHIX Cooling Carrier is an optional add-on to the PHIX Characterization Package. It consists of a thermoelectric cooler (TEC) on a mounting base suitable for easy connection to an optical table or heatsink. The unit provides cooling to the packaged photonic integrated circuit (PIC) and, in combination with a thermistor and TEC controller, it allows the PIC to be kept at a constant temperature.

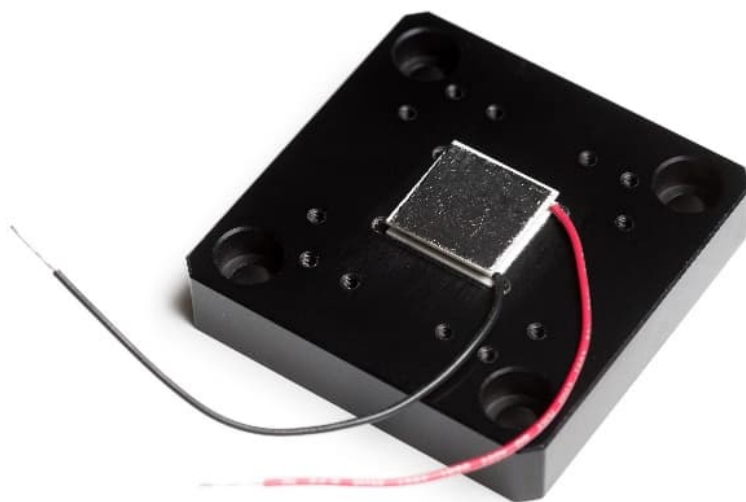

Key features

- Works in conjunction with the PHIX Characterization Package and its integrated thermistor
- Mounting base with 2" (50.8 mm) hole pattern for mounting on optical baseplates
- Durable thermal interface pad suitable for replacing the Characterization Package connected to the Cooling Carrier.
- Powerful TEC for up to 20W of continuous cooling power at convenient 5V operation (4A).

2 Mounting base

The dimensions of the aluminum cooling carrier mounting base are shown in figure 1 below. It is supplied with 6 (4 functional, 2 spare) M2.5 screws for mounting the PHIX Characterization package.

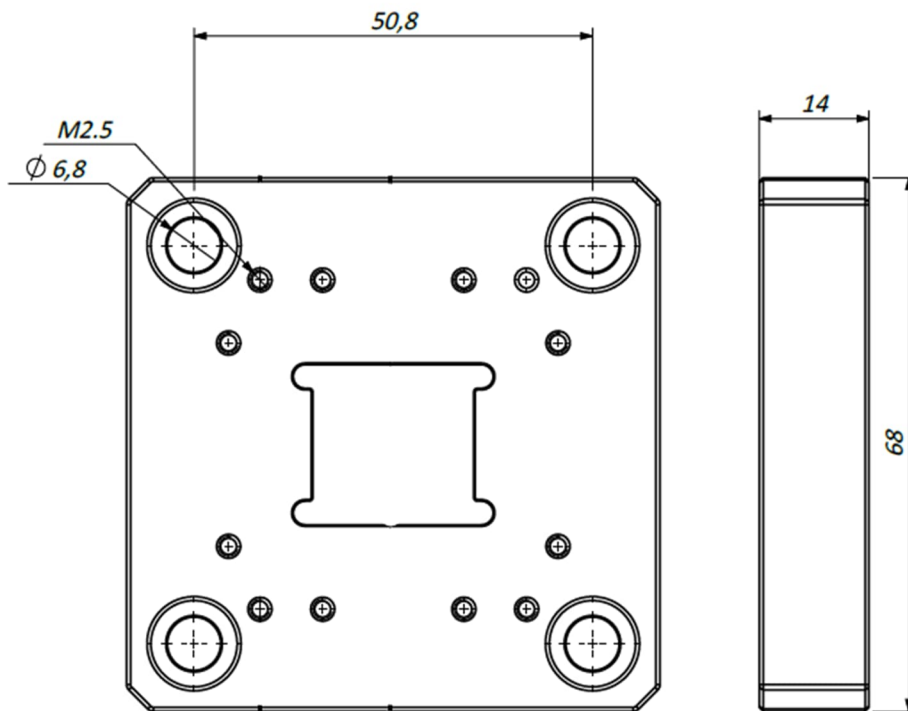

Figure 1: PHIX Cooling Carrier mounting base dimensions

3 Thermoelectric cooler (TEC)

3.1 TEC specifications

The cold side of the thermoelectric cooler (TEC) can be identified as the side with markings on it. This is also the side where the thermal interface pad is applied. The red wire is the positive pole for cooling and the blue or black wire is the negative pole. If heating is required, the polarity can simply be reversed.

Parameters		Remarks
Internal Resistance	1.05Ω ±10%	Measured by AC 4-terminal method at 25°C
I _{max}	6A	Maximum current at T _{max}
V _{max}	8.8V	Maximum voltage at T _{max}
-	T _{hot} = 27°C T _{hot} = 50°C	-
Q _{max}	27.9W 32.7W	Max. cooling capacity at I _{max} , V _{max} and ΔT = 0°C
ΔT _{max}	70°C 77°C	Max. temperature difference at I _{max} , V _{max} and Q = 0 W (Max. parameters are measured in a vacuum 1.3 P)
Solder melting point	235°C	This is the solder melting point of the thermoelectric module
Max. compression	1MPa	Recommended maximum compression (not the destruction limit)
Operating temperature	-40°C to +100°C	

3.2 TEC recommendations

- Take care in handling, because dropping the unit or exerting mechanical shock will cause breakage.
- For optimal reliability and performance it is recommended that the module be utilized at < 0.7·I_{max}.
- For proper cooling performance the aluminum base needs to be mounted onto a heatsinking structure. This could be an optical table or dedicated heatsink with optional fan.
- Suggested TEC controllers:
 - 12W, Thorlabs TED200C (10k Ohm NTC, -45 to 145°C)
 - 4W, Thorlabs TTC001 (10k Ohm NTC, -45 to 125°C)
 - 18W, Thorlabs PTC1 (10k Ohm NTC, 5 to 45°C)
- More info about TEC controllers can be found at: <https://www.laserdiodecontrol.com/tec-controller-basics>

4 Thermistor

4.1 Thermistor types

For standard configurations, the PHIX Characterization Package ships with an integrated negative thermal coefficient (NTC) thermistor placed inside the gold-plated copper base.

For some of our custom packages we make use of a chip NTC, instead of the standard thermistor. This is a smaller component that can be integrated more closely or even onto the PIC.

4.2 Using the thermistor

By measuring the resistance of the thermistor, the temperature of the copper block can be derived. The relationship between temperature and resistance is defined, by approximation, by the thermistor's beta value, but is best determined from a temperature table or calculation tool. The basic characteristics of both models can be found in the table below.

	Standard thermistor	Chip thermistor
Model	Vishay NTCLE300E3103SB	Mitsubishi VH05 series 6D103F
Resistance at 25°C (R ₂₅)	10,000 Ω	10,000 Ω
Beta value	3977 K ($\beta_{25/85}$)	3930 K ($\beta_{25/50}$)
Beta value tolerance	0.75%	1%
Temperature table	Click here	Click here
Other info	Temperature calculator	Datasheet

The relationship between temperature and resistance for the standard thermistor is shown in the graph below.

